

KI-10M Facade fixing with metal pin

Hammer-set facade insulation fixing with steel nail for countersunk installation with additional insulation cap.



Approvals and Reports

- ETA-07/0291



Product information

Features and benefits

- Installation in all base materials (categories A, B, C, D, E)
- Fixing recommend for countersunk installation (with post-installed insulation cap) reduces heat transmission and results in a homogenous insulation surface
- Steel nail allows fast and trouble-free installation with correct expansion of the plug.
- Expansion zone designed for low embedment depths, reducing the amount of drilling required.
- Plate stiffness (value 0.4 kN/mm) ensures smooth elevation surface and stable insulation system.
- Optimal product parameters enable cost-saving solutions.

Applications

- External Thermal Insulation Composite Systems (ETICS)
- Polystyrene (EPS) boards
- Mineral wool (MW) boards
- Light wood wool building boards
- Polyurethane (PU) boards
- Lightweight recycled panels

Base materials

Approved for use in:

- Concrete C20/25-C50/60
- Solid Brick
- Hollow-core Slab
- Solid Sand-lime Brick
- Hollow Sand-lime Brick
- Lightweight Concrete Block
- Hollow Lightweight Concrete Block
- Reinforced components of lightweight aggregate concrete
- Aerated Concrete Block

Installation guide

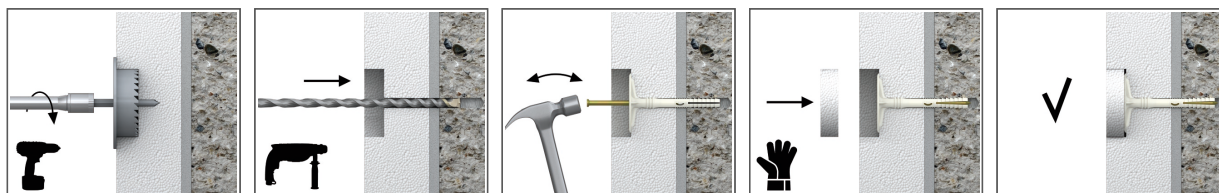

1. Drill a hole of required diameter and depth
2. Lightly tap the plastic sleeve through the insulation material into hole with a hammer, until fixing depth is reached
3. Hammer the steel nail into the plastic sleeve until fixing is secure and flush with insulation material.
4. Embedment depth of min 25mm in base materials category A, B, C (concrete, solid and perforated bricks), 40mm in base materials category D (lightweight concrete blocks) and 60mm in aerated concrete.
5. For countersunk installation cut the hole with KFS tool, insert insulation cap into countersunk hole following installation of the facade fixing
6. In soft insulation panels the fixing should be combined with insulation retaining plates KWL-90, KWL-110, KWL-140.

Product information

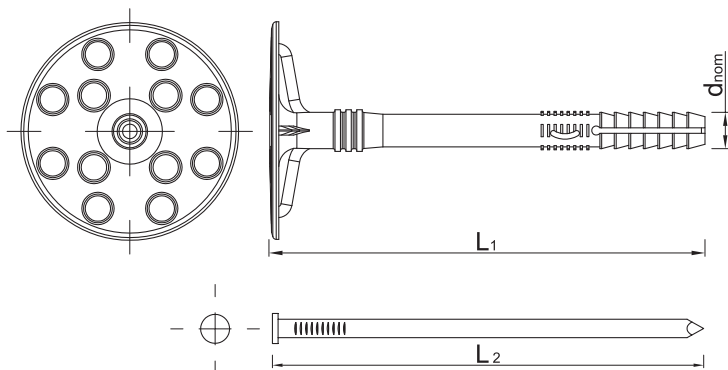

Size	Product Code	Fixing			Fixture		
		Diameter	Length	Plate diameter	Recommended thickness		
		d	L	D	t _{rx} A, B, C	t _{rx} D	t _{rx} E
[mm]							
Ø10	KI-090M	10	90	60	55	40	20
	KI-120M	10	120	60	85	70	50
	KI-140M	10	140	60	105	90	70
	KI-160M	10	160	60	125	110	90
	KI-180M	10	180	60	145	130	110
	KI-200M	10	200	60	165	150	130
	KI-220M	10	220	60	185	170	150
	KI-260M	10	260	60	225	210	190

Installation data

Substrate			A, B, C	D	E
Fixing diameter	d	[mm]	10	10	10
Hole diameter in substrate	d ₀	[mm]	10	10	10
Min. hole depth in substrate	h ₀	[mm]	35	50	70
Min. installation depth	h _{nom}	[mm]	25	40	60
Min. substrate thickness	h _{min}	[mm]	100	100	100
Min. spacing	s _{min}	[mm]	100	100	100
Min. edge distance	c _{min}	[mm]	100	100	100

Basic performance data

Performance data for single anchor without influence of edge distance and spacing

Substrate		Concrete C12/15	Concrete min. C16/20	Solid brick	Sand-lime solid brick	Sand-lime hollow brick	Perforated ceramic brick	Perforated ceramic brick (i.e. Porotherm)	MEGA MAX	Hollow lightweight concrete block	Lightweight concrete solid block	Aerated concrete
		Effective embedment depth h _{ef}	[mm]	25	25	25	25	25	25	25	25	40
MEAN ULTIMATE LOAD N _{RM,m}												
KI-10M	[kN]	0.92	0.97	0.77	1.11	1.01	0.74	0.57	0.67	0.75	0.98	0.17
CHARACTERISTIC LOAD N _{Rk}												
KI-10M	[kN]	0.50	0.50	0.40	0.60	0.50	0.40	0.30	0.30	0.40	0.60	0.10
DESIGN LOAD N _{Rd}												
KI-10M	[kN]	0.25	0.25	0.20	0.30	0.25	0.20	0.15	0.15	0.20	0.30	0.05

Basic performance data

Substrate	RECOMMENDED LOAD N _{rec}											
	Concrete C12/15	Concrete min. C16/20	Solid brick	Sand-lime solid brick	Sand-lime hollow brick	Perforated ceramic brick	Perforated ceramic brick (i.e. Porotherm)	MEGA MAX	Hollow lightweight concrete block	Lightweight concrete solid block	Aerated concrete	
KI-10M	[kN]	0.18	0.18	0.14	0.21	0.18	0.14	0.11	0.11	0.14	0.21	0.04

Fixing type	KI-10M	
Plate resistance	[kN]	2.6
Plate stiffness	[kN/mm]	0.4
Point thermal transmittance	[W/K]	0,003 - 0,006

Product commercial data

Size	Product Code	Fixing			Quantity [pcs]			Weight [kg]			Bar Codes
		Diameter [mm]	Length [mm]	Plate diameter [mm]	Box	Outer	Pallet	Box	Outer	Pallet	
Ø10	KI-090M	10	90	60	250	250	12000	6.0	6.0	317.8	5906675212142
	KI-120M	10	120	60	250	250	10000	7.4	7.4	323.8	5906675212241
	KI-140M	10	140	60	250	250	8000	8.6	8.6	303.9	5906675212340
	KI-160M	10	160	60	250	250	8000	9.3	9.3	327.8	5906675212449
	KI-180M	10	180	60	250	250	6000	10.4	10.4	279.0	5906675212548
	KI-200M	10	200	60	250	250	6000	11.4	11.4	303.3	5906675212647
	KI-220M	10	220	60	250	250	6000	12.0	12.0	319.0	5906675212746
KI-260M	10	260	60	200	200	4800	11.1	11.1	295.6	5906675212845	