

KI-10N Long expansion zone facade fixing with metal pin

Hammer-in facade fixing 60mm long expansion zone for high performance in masonry, as well as lightweight and aerated concrete



Approvals and Reports

- ETA-07/0221



Product information

Features and benefits

- Easy installation with best performance in lightweight base materials
- Approved for use in base material categories B, C, D, and E
- Steel nail allows fast and trouble-free installation with correct expansion of the plug.
- Reduction of thermal bridge formation (value 0.3W/K) through the integration of an impact-resistant plastic overmoulding on the nail head.
- Plate stiffness (value 0.5 kN/mm) ensures smooth elevation surface and stable insulation system.
- Can be used with additional KWL insulation holding plate, available in 90, 110 and 140mm flange sizes.

Applications

- External Thermal Insulation Composite Systems (ETICS)
- Polystyrene (EPS) boards
- Mineral wool (MW) boards
- Light wood wool building boards
- Polyurethane (PU) boards
- Lightweight recycled panels

Base materials

Approved for use in:

- Solid Brick (Use category B)
- Hollow Brick (Use category C)
- Vertically-perforated clay block (Use category C)
- Lightweight Concrete Block (Use category C)
- Reinforced components of lightweight aggregate concrete (Use category D)
- Aerated Concrete Block (Use category D)

Installation guide

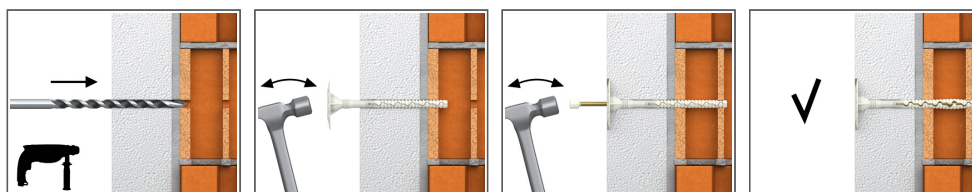

1. Drill a hole of required diameter and depth
2. Drilling depth of min 80mm in approved materials.
3. Lightly tap the plastic sleeve through the insulation material into hole with a hammer, until fixing depth is reached
4. Embedment depth of min 60mm in approved materials.
5. Hammer the steel nail into the plastic sleeve until fixing is secure and flush with insulation material.
6. In soft insulation panels the fixing should be combined with insulation retaining plates KWL-90, KWL-110, KWL-140.
7. Temperature range when installed -35C to +80C.

Product information

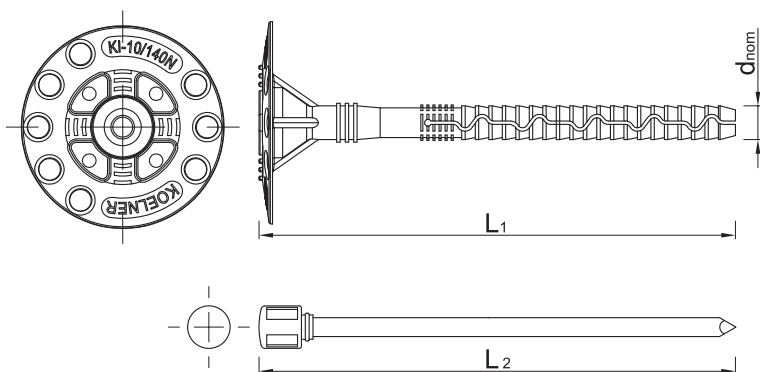

Size	Product Code	Fixing			Fixture
		Diameter	Length	Plate diameter	Recommended thickness
		d	L	D	t _{fix} B, C, D, E
[mm]					
Ø10	KI-140N	10	140	60	70
	KI-160N	10	160	60	90
	KI-180N	10	180	60	110
	KI-200N	10	200	60	130
	KI-220N	10	220	60	150
	KI-260N	10	260	60	190
	KI-300N	10	300	60	210

Installation data

Substrate			B, C, D, E
Fixing diameter	d	[mm]	10
Hole diameter in substrate	d ₀	[mm]	10
Min. hole depth in substrate	h ₀	[mm]	70
Min. installation depth	h _{nom}	[mm]	60
Min. substrate thickness	h _{min}	[mm]	100
Min. spacing	s _{min}	[mm]	100
Min. edge distance	c _{min}	[mm]	100

Basic performance data

Performance data for single anchor without influence of edge distance and spacing

Substrate		Solid brick	Calcium silicate hollow	Hollowed brique	Perforated ceramic brick	Vertical perforated poro-sited block	Lightweight concrete	Aerated concrete AAC2	Aerated concrete AAC5
		Effective embedment depth h _{ef}	[mm]	60	60	60	60	60	60
MEAN ULTIMATE LOAD N_{RM,m}									
KI-10N	[kN]	1.21	1.00	0.89	1.29	0.83	1.15	1.04	1.31
CHARACTERISTIC LOAD N_{Rk}									
KI-10N	[kN]	0.75	0.50	0.40	0.60	0.40	0.60	0.30	0.90
DESIGN LOAD N_{Rd}									
KI-10N	[kN]	0.38	0.25	0.20	0.30	0.20	0.30	0.15	0.45
RECOMMENDED LOAD N_{rec}									
KI-10N	[kN]	0.27	0.18	0.14	0.21	0.14	0.21	0.11	0.32

Basic performance data

Fixing type		KI-10N
Plate resistance	[kN]	1.23
Plate stiffness	[kN/mm]	0.5
Point thermal transmittance	[W/K]	0.003

Product commercial data

Size	Product Code	Fixing			Quantity [pcs]			Weight [kg]			Bar Codes
		Diameter [mm]	Length [mm]	Plate diameter [mm]	Box	Outer	Pallet	Box	Outer	Pallet	
Ø10	KI-140N	10	140	60	250	250	8000	8.5	8.5	301.0	5906675218144
	KI-160N	10	160	60	250	250	8000	9.5	9.5	333.6	5906675218243
	KI-180N	10	180	60	250	250	6000	10.5	10.5	280.7	5906675218342
	KI-200N	10	200	60	250	250	6000	11.5	11.5	305.9	5906675218441
	KI-220N	10	220	60	250	250	6000	12.2	12.2	323.9	5906675218540
	KI-260N	10	260	60	200	200	4800	11.3	11.3	301.5	5906675218748
	KI-300N	10	300	60	200	200	4800	12.5	12.5	329.6	5906675218649